

EN7 FAULT DIAGNOSIS BY SELF-DIAGNOSIS SYSTEM

1. POWER SUPPLY AND EARTH CIRCUIT

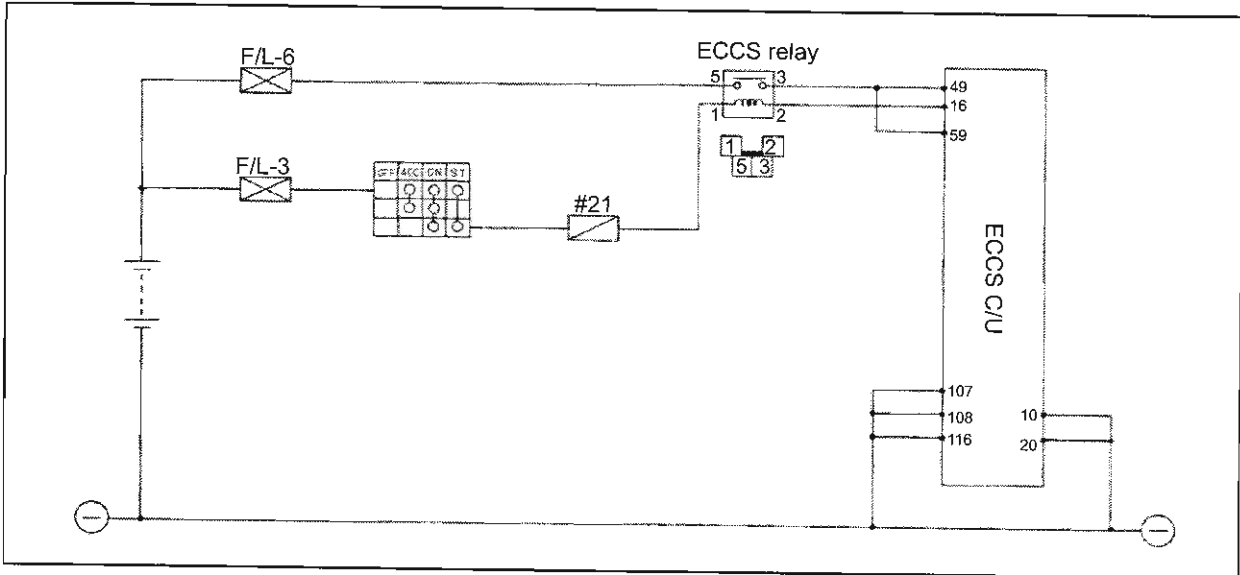

A

Power supply inspection

- Place ignition switch in the ON position.
- Check power voltage using "battery voltage" in data monitor mode.
- Use tester to measure power voltage between ECCS C/U terminal 49, 50 and body earth.

OK

A

☆ MONITORING ☆ NO FAULT

CAS.RPM (POS)	1062rpm
POWER VOL	14.0V

START MONITORING

B

Ground circuit inspection

- Place ignition switch to OFF position. Remove ECCS C/U harness connector.
- Check for harness continuity between ECCS C/U terminal 10, 20, 107, 108, 116 and body earth. If NG repair faulty harness or connectors.

NG

A

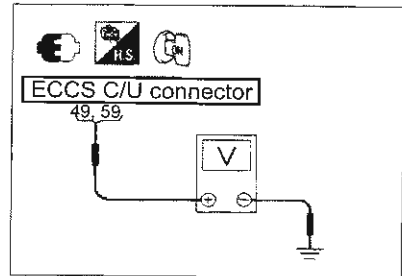

B

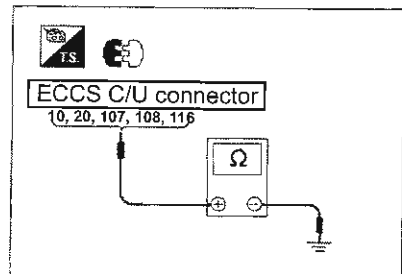

C

Harness continuity inspection

- Place ignition switch to OFF position.
- Disconnect ECCS C/U and ECCS relay harness connector.
- Check for continuity between ECCS C/U terminal 49, 59 and ECCS relay terminal 3.

NG

FINISH

Faulty harness or connector.

OK

TO D

D

Voltage inspection between ECCS C/U terminal and earth

- Place ignition switch to ON position.
- Measure power voltage between ECCS relay terminal 2, 3 and earth.

If NG place ignition switch to OFF position. Inspect the continuity between ECCS relay and the battery.

OK

Repair faulty harness or connector.

NG

E

Output signal circuit inspection

Check for continuation between ECCS C/U terminal 16 and terminal 1.

OK

Inspect the following:
Ignition coil harness connector.
Harness between ECCS C/U and ECCS relay.
If NG repair faulty harness or connector.

NG

Component parts inspection

- Check ECCS relay.

OK

Repair ECCS relay

NG

Inspect ECCS C/U terminal for any damage and ECCS C/U connector connections.

C

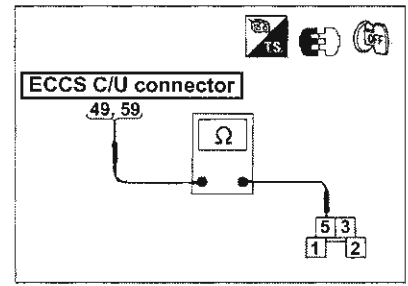

D

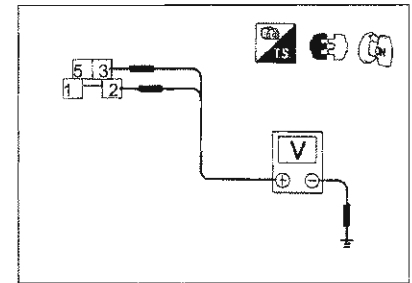

E

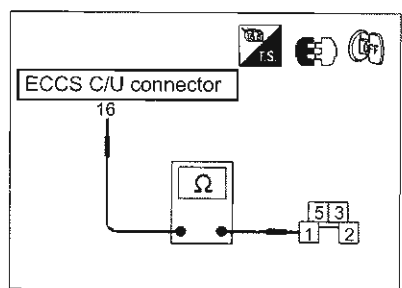

2. CRANK ANGLE SENSOR SYSTEM (SELF-DIAGNOSIS DISPLAY 11)

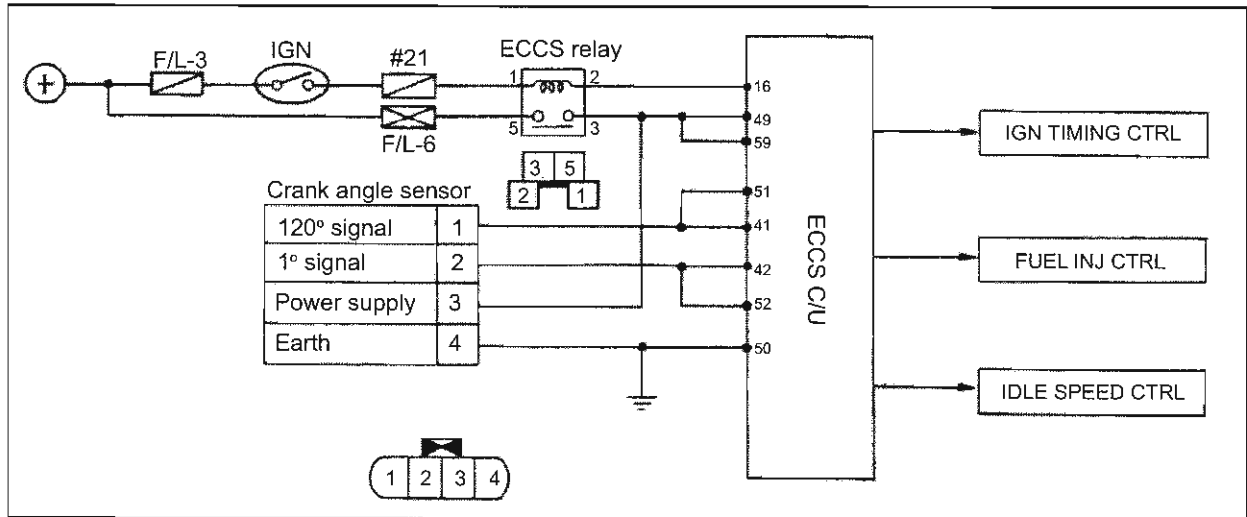

A

Power supply inspection

- Place ignition switch to OFF position.
- Remove crank angle sensor harness connectors.
- Place ignition switch in the ON position.
- Use tester to measure the voltage between terminal 3 and body earth.

NG

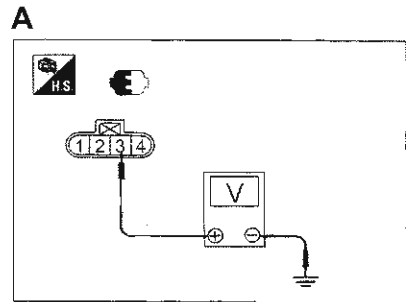

OK

Inspect the following:
Check the continuity between crank angle sensor terminal 3 and ECCS relay terminal 3.
If NG repair faulty harness or connectors.

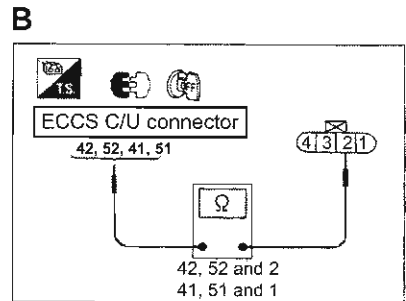

B

Input signal circuit inspection

- Place ignition switch in the OFF position.
- Disconnect ECCS C/U harness connectors.
- Check for continuity between crank angle sensor terminal 2 and ECCS C/U terminal 42, 52 (1° signal), between crank angle sensor terminal 1 and ECCS C/U terminal 41, 51 (120° signal).

NG



Repair faulty harness or connector

OK

TO C

C

Input signal inspection

- Connect crank angle sensor and ECCS C/U harness connectors.
- Use "CAS. RPM" in data monitor mode to measure engine speed. 
- Measure the voltage between ECCS C/U terminal 41, 42, 52, 51 and ground. 

Voltage	Terminal 42, 52	Terminal 41, 51
Ignition sw ON	0V or approx.5V	0V or approx.5V
Cranking	Approx. 5V	Approx. 2 ~ 3V
Idling	Approx. 0.3~0.7V	Approx. 2 ~ 3V

NG

OK

Component parts inspection

- Check crank angle sensor.
If NG replace crank angle sensor.

Inspect ECCS C/U terminal for any damage and ECCS C/U connector connections.

C

☆ MONITORING ☆ NO FAULT

CAS.RPM (REF)	662rpm
AIR FLOW MTR	1.02V
ENG TEMP SEN	81°
EXH SEN	0.18V
THROTTLE SEN	0.38V
INJ PULSE	3.0msec

START MONITORING

C

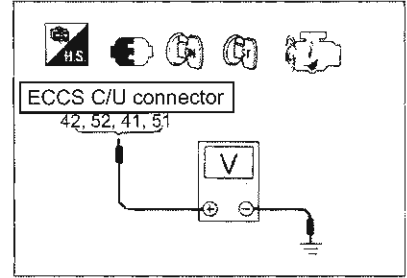

3. AIR FLOW METER SYSTEM (SELF-DIAGNOSIS DISPLAY 12)

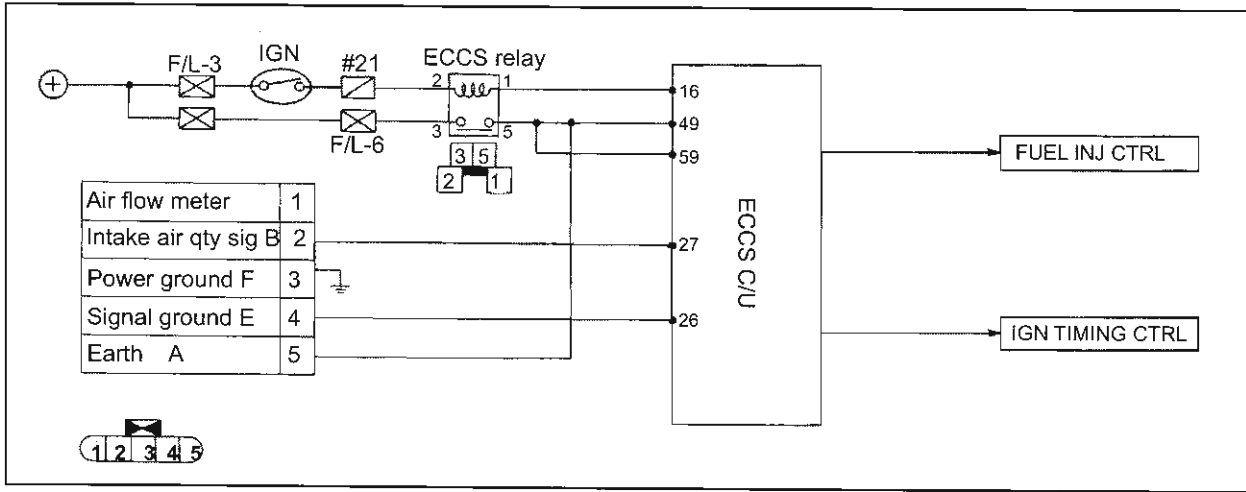

A

Power supply inspection

- Place ignition switch in the OFF position.
- Remove air flow meter harness connector.
- Place ignition switch in the ON position.
- Use tester to measure the voltage between terminal 3 and body earth.

A

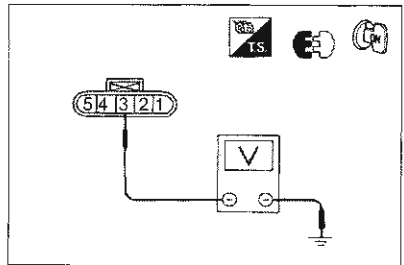

OK

Inspect the following:

- Check for continuity between air flow meter terminal 5 and ECCS relay terminal 3.

If NG repair harness or connectors.

B

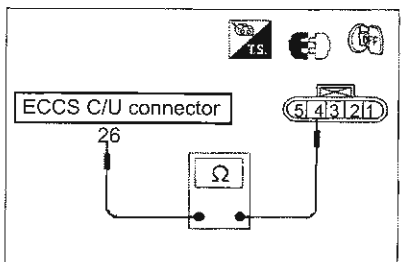

B

Ground circuit inspection

- Place ignition switch to OFF position.
- Remove ECCS C/U harness connectors.
- Check for continuity between terminal 4 and ECCS C/U terminal 26.

C

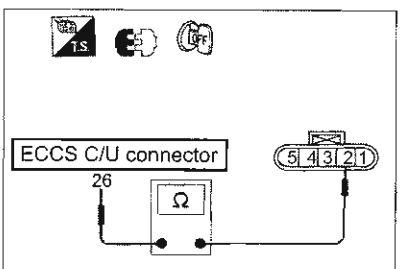

OK

Repair harness or connector.

C

Input signal inspection

Check for continuity between air flow meter terminal 2 and ECCS C/U terminal 27 (intake air quantity signal).

NG



Repair harness or connector.

OK

TO D

D

Input signal inspection

- Connect air flow meter and ECCS C/U harness connectors.
- Use "AIR FLOW METER" in data monitor mode to measure input signal. 
- Measure the voltage between ECCS C/U terminal 27 and body earth. 

Voltage	Terminal 27
Ignition sw in ON	Approx. 0.3V
Cranking	Approx. 1V
Idling	Approx. 1.1V

OK

NG

Component parts inspection

- Check air flow meter.
- If NG replace air flow meter.

Inspect ECCS C/U terminal for any damage and ECCS C/U connector connections.

D

☆ MONITORING ☆ NO FAULT

CAS.RPM (REF)	662rpm
AIR FLOW MTR	1.02V
ENG TEMP SEN	81°C
EXH SEN	0.18V
THROTTLE SEN	0.40V
INJ PULSE	3.0msec

START MONITORING

D

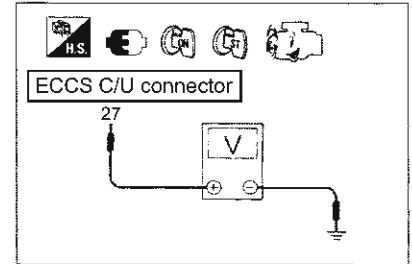

4. WATER TEMPERATURE SENSOR SYSTEM (SELF-DIAGNOSIS DISPLAY 13)

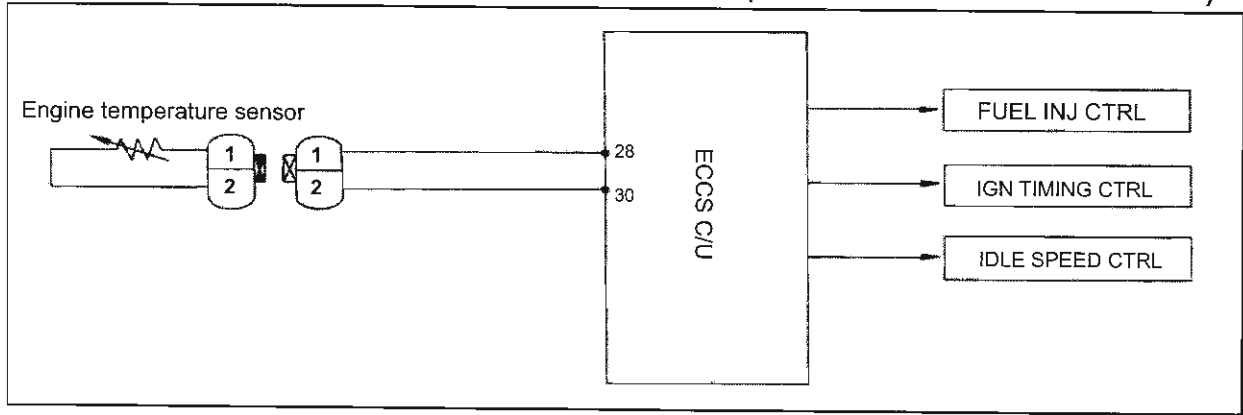

A

Power supply inspection

- Place ignition switch in the OFF position.
- Remove engine temperature sensor harness connector.
- Place ignition switch in the ON position.
- Use tester to measure power voltage between terminal 1 and body earth.

Voltage: Approx. 5V

A

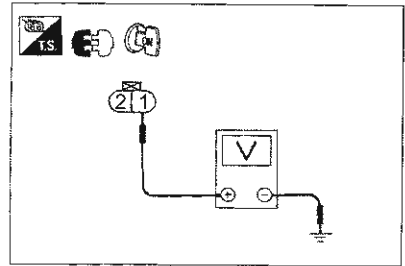

OK

Repair faulty harness or connector.

NG

B

Earth circuit inspection

- Place ignition switch in the OFF position.
- Check for continuity between terminal 2 and body earth.

B

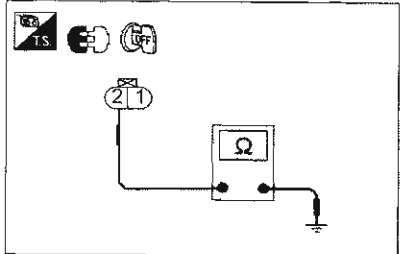

OK

Repair faulty harness or connector.

NG

C

Input signal inspection

- Use "ENG TEMP SENSOR" in data monitor mode to check engine coolant temperature.
- Check the power voltage between ECCS C/U terminal 28 and earth.

Ignition switch in ON position

Eng temp Approx. 20°C:	3V
Approx. 80°C:	1V

C

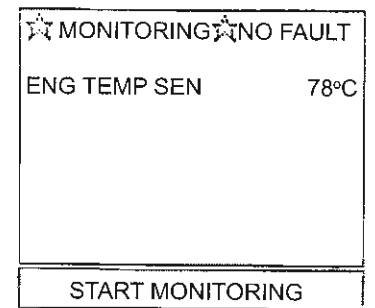

OK

Component parts inspection

- Check water temperature sensor.
- If NG replace crank angle sensor.

C

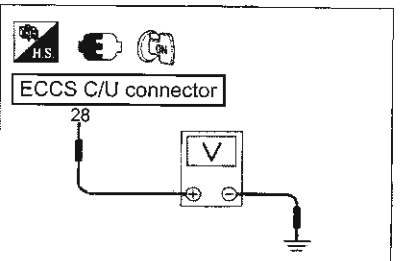

Inspect ECCS C/U terminal for any damage and ECCS C/U connector connections.

5. IGNITION SYSTEM (SELF-DIAGNOSIS DISPLAY 21)

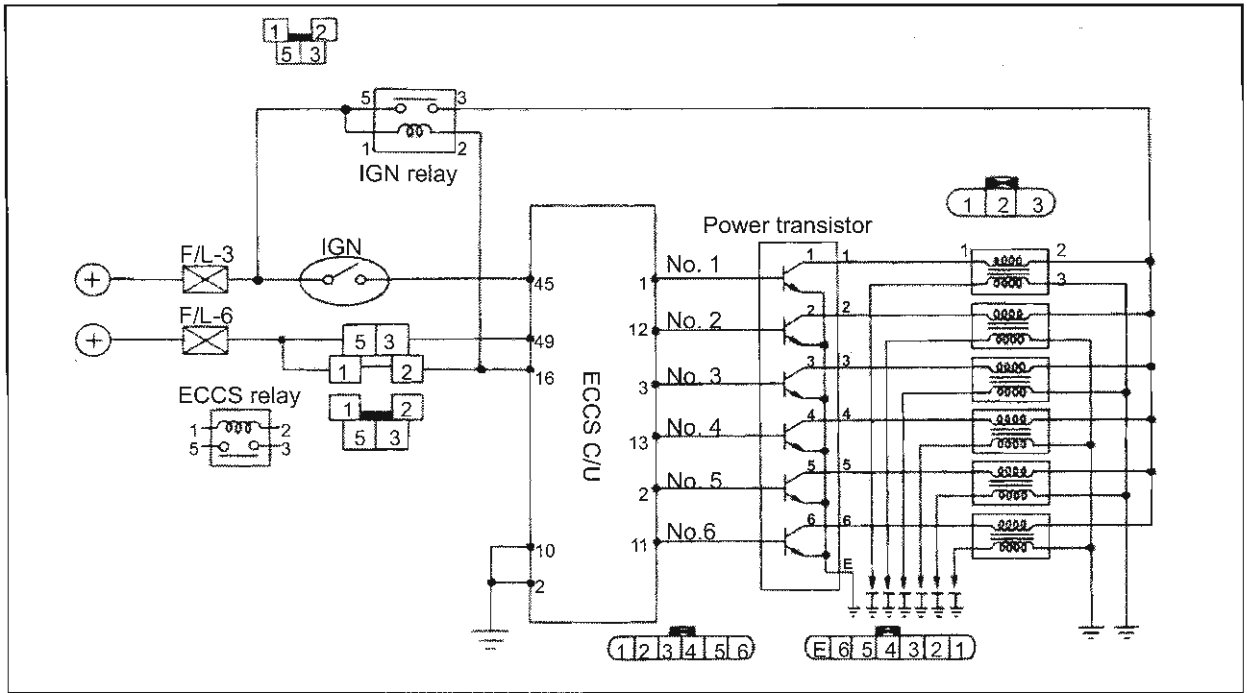

A

Circuit function inspection

- Inspect using "Power balance" in function test mode.
- Check if engine rev will decrease momentarily.

OK

B

Earth circuit inspection

- Place ignition switch to OFF position.
- Remove power transistor unit harness connector.
- Check for harness continuity between terminal E and earth.

NG

Repair faulty harness or connector

TO C

A

◆ SELF-DIAG RES ◆

FAILURE DETECTED TIME
IGN SIGNAL PRIMARY 0

ERASE PRINT

A

◆ POWER BALANCE ◆

INSPECT THE BALANCE OF EACH CYLINDER BY STOPPING INJECTOR OPERATION FOR EACH CYLINDER.

PASS START

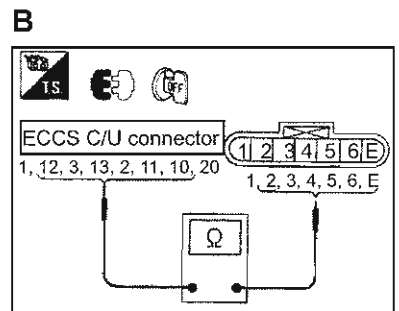

C

Output signal circuit inspection

- Place ignition switch to OFF position.
- Remove ECCS C/U harness connector.
- Check for continuity between following terminals:

ECCS C/U terminal 1 & 2
 ECCS C/U terminal 12 & 2
 ECCS C/U terminal 3 & 3
 ECCS C/U terminal 13 & 4
 ECCS C/U terminal 2 & 5
 ECCS C/U terminal 11 & 6
 ECCS C/U terminal 10 & E
 ECCS C/U terminal 20 & E

NG

OK

Repair faulty harness or connector.

D

Output signal inspection

- Connect power transistor unit and ECCS C/U harness connectors.
- Check for power voltage between ECCS C/U terminals 1, 2, 3, 11, 12, 13 and body earth.

Cranking: Approx. 0.2 ~ 0.3V
 Idling: Approx. 0.2 ~ 0.3V
 2500rpm: Approx. 1V

NG

OK

Repair faulty harness or connector.

Component parts inspection

- Check power transistor unit.
- If NG replace power transistor unit.

OK

Inspect ECCS C/U terminal for any damage and ECCS C/U connector connections.

6. O₂ SENSOR SYSTEM (SELF-DIAGNOSIS DISPLAY 15)

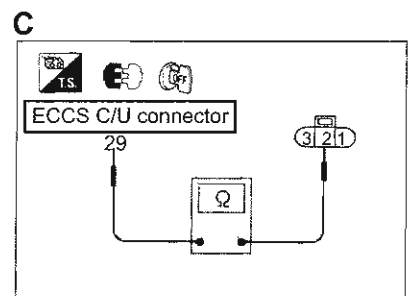
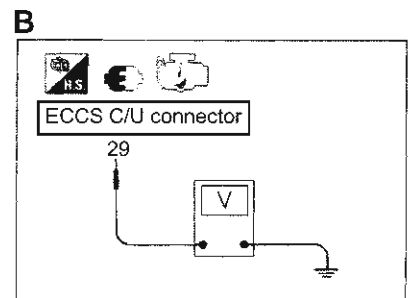
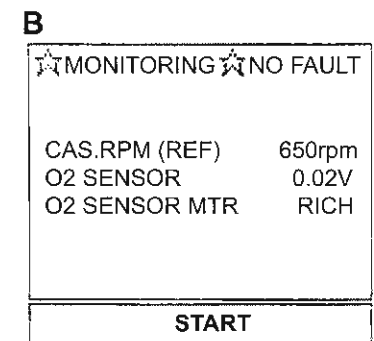
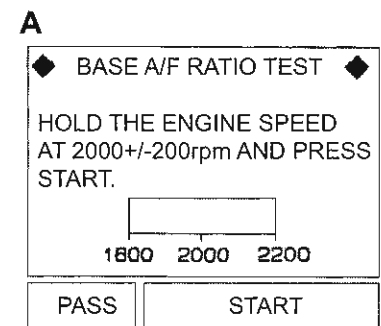
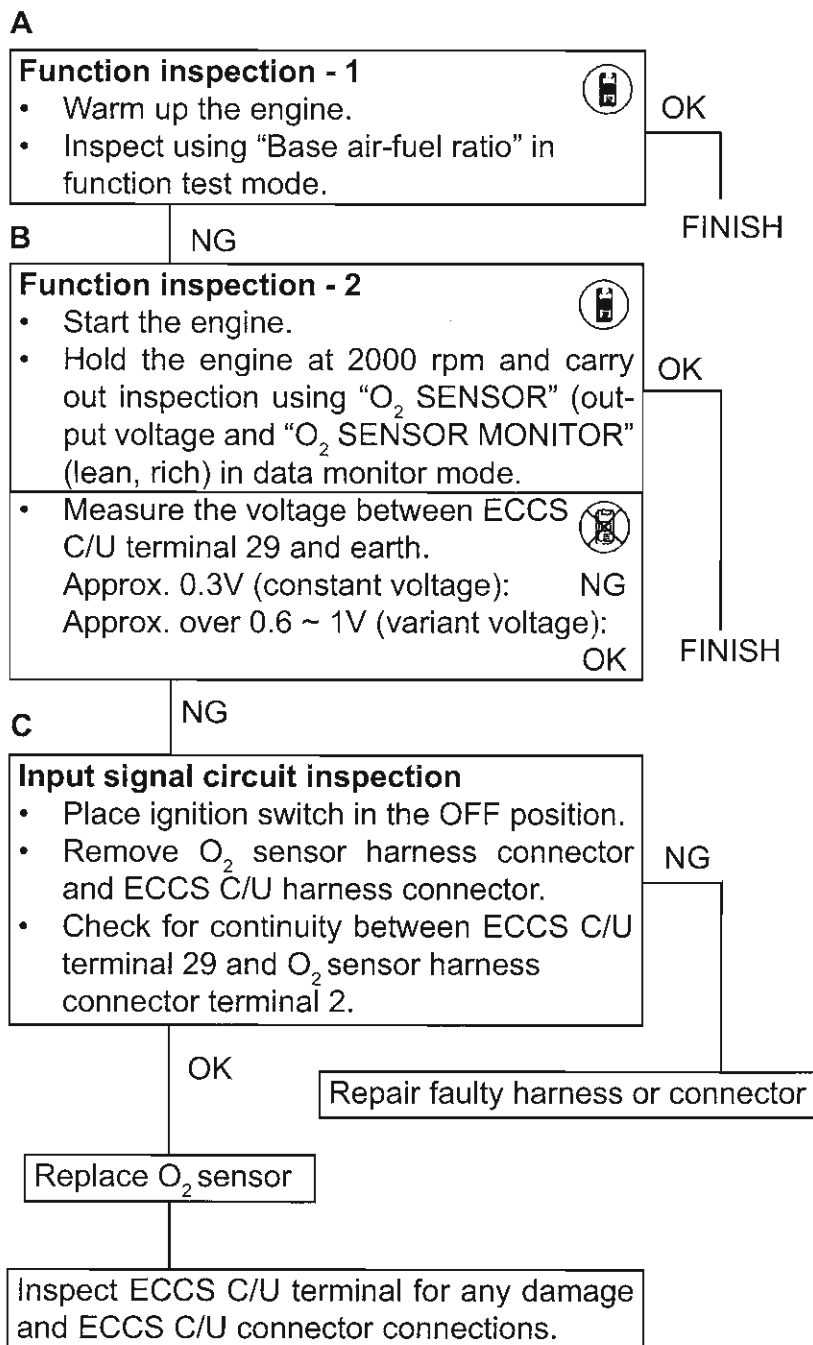
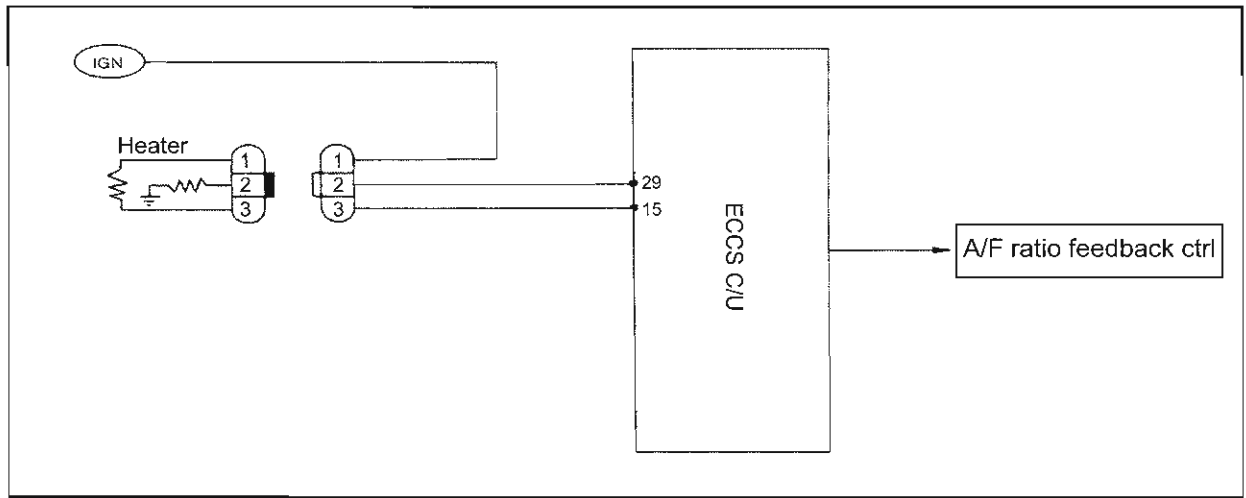

7. DETONATION SENSOR SYSTEM (SELF-DIAGNOSIS DISPLAY 34)

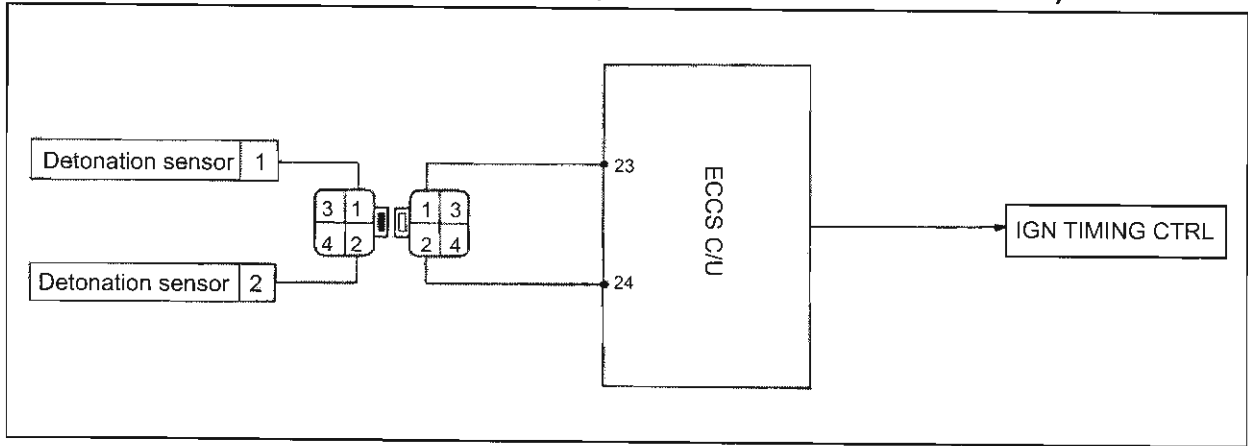

A

Input signal circuit inspection - 1

- Place ignition switch in the OFF position.
- Remove ECCS C/U harness connector and sub harness connector.
- Check for continuity between terminal 1 and ECCS C/U terminal 23, terminal 2 and ECCS C/U terminal 24.

NG

OK

Repair faulty harness or connector

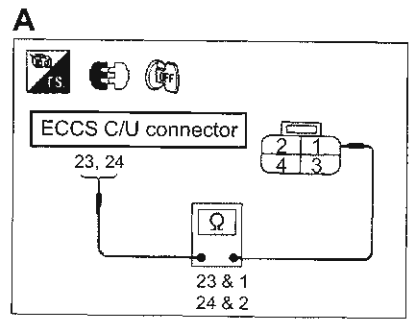

B

Input signal circuit inspection - 2

- Remove harness connectors connected at front & rear of the knock sensor.
- Check for continuity between sub harness terminal A and 23, B and 24.

NG

OK

Repair faulty harness or connector

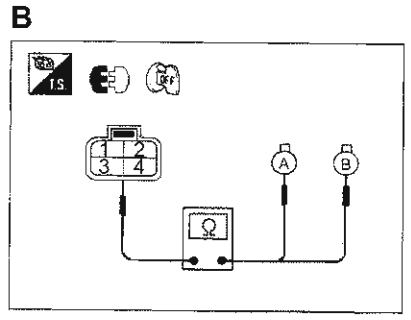

C

Input signal inspection

- Connect knock sensor and ECCS C/U harness connectors.
- Measure the voltage between ECCS C/U terminal 23, 24 and earth.

NG

OK

Replace knock sensor

Voltage	Terminal 23, 24 and earth
Ignition in ON	Approx. 4V
Cranking	Approx. 4V
Idling	Approx. 4V

Inspect ECCS C/U terminal for any damage and ECCS C/U connector connections.

8. THROTTLE SENSOR SYSTEM (SELF-DIAGNOSIS DISPLAY 43)

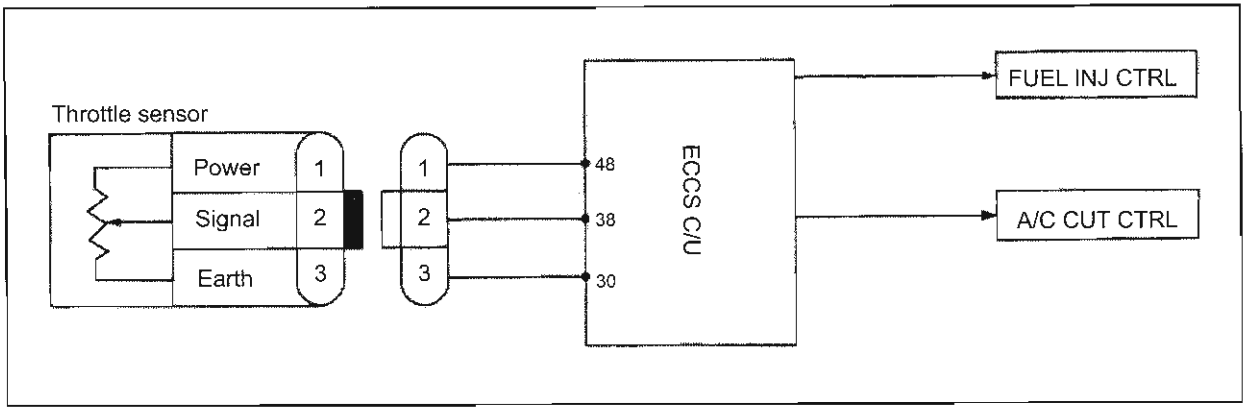

A

System inspection

- Place ignition switch in the ON position.
- Use "THROTTLE SENSOR" in data monitor mode to inspect the system.

Voltage

Fully open	Approx. 4.0V
Fully closed	Approx. 0.6V
Open / Close range over	Approx. 3.0

OK

A

◆ THROTTLE SENSOR ◆

PRESS START WHILE DEPRESSING THE ACCELERATOR PEDAL FULLY.

PASS START

B

NG

Power supply inspection

- Place ignition sw in the ON position.
- Use "THROTTLE SENSOR" in data monitor mode to carry out inspection.
- Place ignition sw in the OFF position.
- Remove throttle sensor harness connector. Measure the power voltage between terminal 1 and earth.

Power voltage: Approx. 5V

NG

B

☆ MONITORING ☆ NO FAIL

CAS.RPM (REF)	0rpm
THROTTLE SEN	3.94V

START

Repair faulty harness or connector

C

- Remove ECCS C/U harness connector.
- Check for continuity between ECCS C/U terminal 38 and 2.

NG

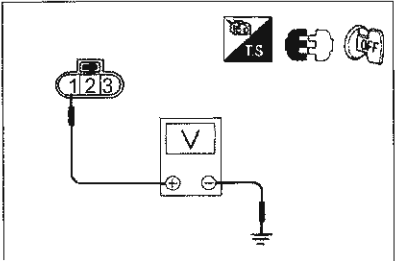

Repair faulty harness or connector

Component parts inspection

- Inspect throttle sensor.

If NG replace throttle sensor unit.

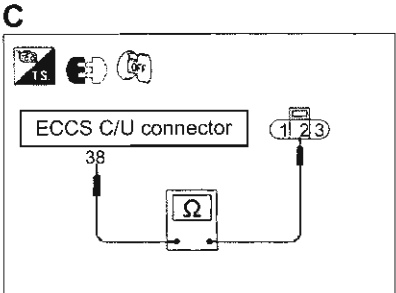

OK

Inspect ECCS C/U terminal for any damage and ECCS C/U connector connections.

9. A/T CONTROL SYSTEM (SELF-DIAGNOSIS DISPLAY 54)

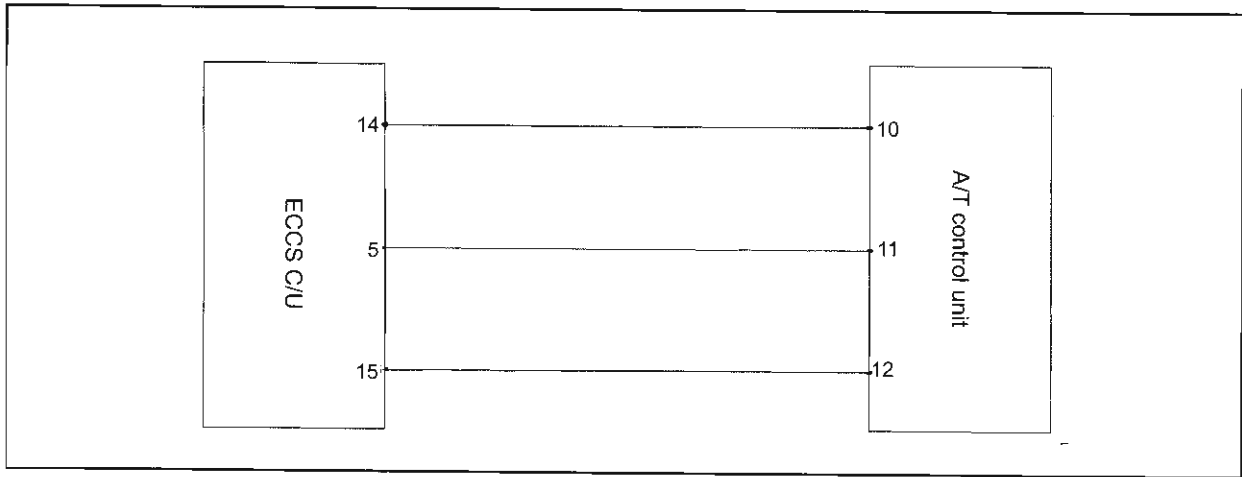

A

Input signal circuit inspection

- Place ignition switch in the OFF position.
- Remove ECCS C/U harness and A/T C/U harness connectors.
- Check the continuity between ECCS C/U terminal 14 and A/T C/U terminal 10, ECCS C/U terminal 5 and A/T C/U terminal 11.

NG

Repair faulty harness or connector

OK

Inspect ECCS C/U terminal for any damage and ECCS C/U connector connections.

A

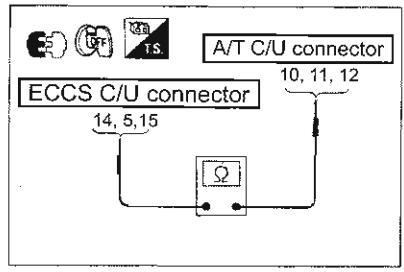

10. CRANK ANGLE SENSOR SYSTEM (NOT IN SELF-DIAGNOSIS)

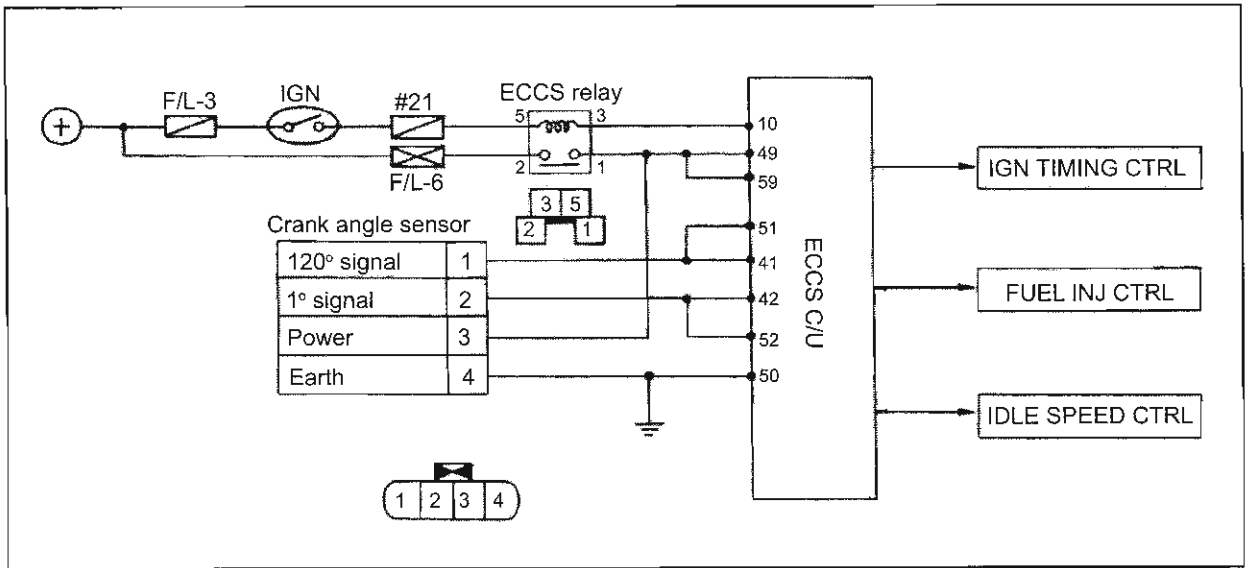

A

Earth circuit inspection

- Place ignition switch to OFF position.
- Remove crank angle sensor harness connector.
- Check for continuity between terminal 4 and body earth.

NG

Repair faulty harness or connector.

OK

Component parts inspection

- Check crank angle sensor.
- If NG replace crank angle sensor.

NG

Replace crank angle sensor.

OK

Inspect ECCS C/U terminal for any damage and ECCS C/U connector connections.

A

